

**6.0A GLASS PASSIVATED BRIDGE RECTIFIER**

**Reverse Voltage - 100 to 1000 V**

**Forward Current – 6.0A**

**FEATURES**

- ◆ Surge overload rating-150 amperes peak
- ◆ Polarity:As marked on body
- ◆ Ideal for printed circuit board
- ◆ Plastic material has U/L

The flammability classification 94V-0

- ◆ Reliable low cost construction utilizing molded plastic technique

**MECHANICAL DATA**

- ◆ Case: KBL
- ◆ Terminals: Solderable per MIL-STD-202, Method 208
- ◆ Approx. Weight: 5.6g /0.2oz

**Maximum Ratings and Electrical characteristics**

Ratings at 25 °C ambient temperature unless otherwise specified.

Single phase half-wave 60 Hz, resistive or inductive load, for capacitive load current derate by 20 %.

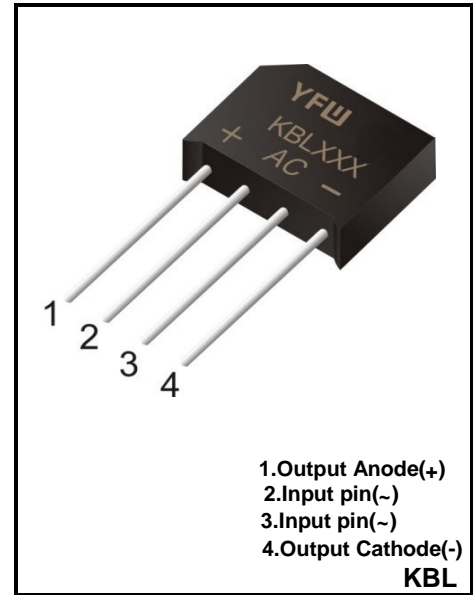

Parameter	Symbols	KBL601	KBL602	KBL604	KBL606	KBL608	KBL610	Units	
Maximum Repetitive Peak Reverse Voltage	$V_{RRM}$	100	200	400	600	800	1000	V	
Maximum RMS voltage	$V_{RMS}$	70	140	280	420	560	700	V	
Maximum DC Blocking Voltage	$V_{DC}$	100	200	400	600	800	1000	V	
Maximum Average Forward Rectified Current at $T_C=100^{\circ}C$ (Note 1)	$I_{(AV)}$					6.0 3.5			A
Peak Forward Surge Current 8.3 ms Single Half Sine-Wave Superimposed on Rated Load (JEDEC method)	$I_{FSM}$					150			A
Forward Voltage per element at 3.0A DC and 25°C	$V_F$					1.0			V
Maximum DC Reverse Current at Rated DC Blocking Voltage @Ta=25°C @Ta=125°C	$I_R$					10 500			μA
I2t Rating for Fusing(3ms≤t≤8.3ms)	$I^2t$					175			A <sup>2</sup> S
Typical Junction Capacitance (Note1)	$C_J$					105			pF
Typical Thermal Resistance (Note2)	$R_{\theta JA}$					20			°C/W
Operating and Storage Temperature Range	$T_j, T_{stg}$					-55 ~ +150			°C

(1) Measured at 1 MHz and applied reverse voltage of 4 V D.C

(2) Unit case mounted on 7.5" x 7.5" x 0.3cm" Al plate heat sink.

**Ratings And Characteristic Curves**

AVERAGE FORWARD RECTIFIED CURRENT, AMPERES

**FIG. 1- FORWARD CURRENT DERATING CURVE**

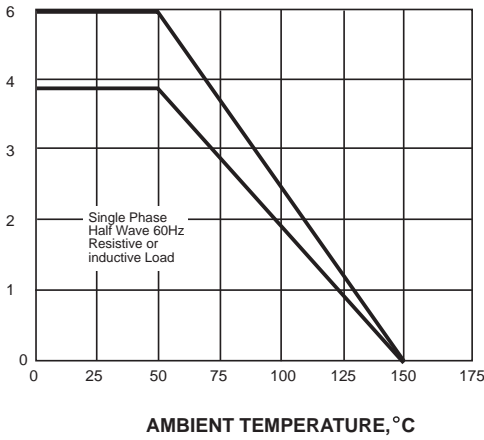

PEAK FORWARD SURGE CURRENT, AMPERES

**FIG. 2-MAXIMUM NON-REPETITIVE PEAK FORWARD SURGE CURRENT**

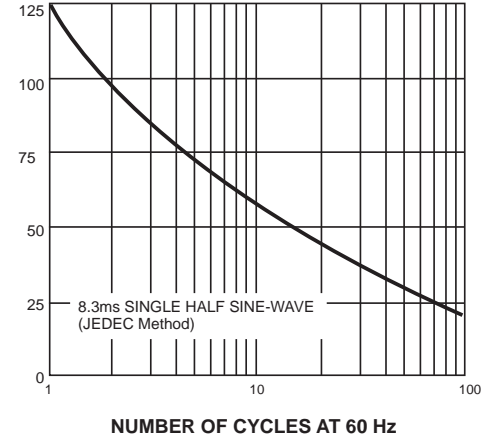

INSTANTANEOUS FORWARD CURRENT, AMPERES

**FIG. 3-TYPICAL INSTANTANEOUS FORWARD CHARACTERISTICS**

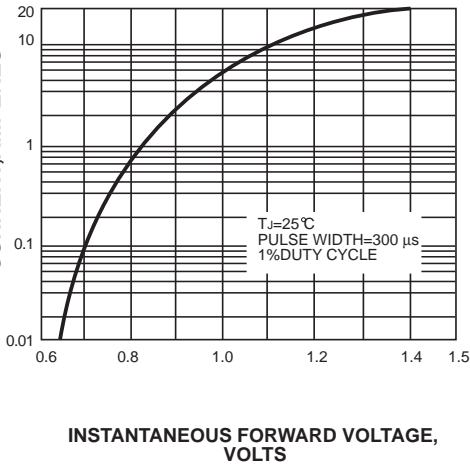

INSTANTANEOUS REVERSE CURRENT, MICROAMPERES

**FIG. 4-TYPICAL REVERSE CHARACTERISTICS**

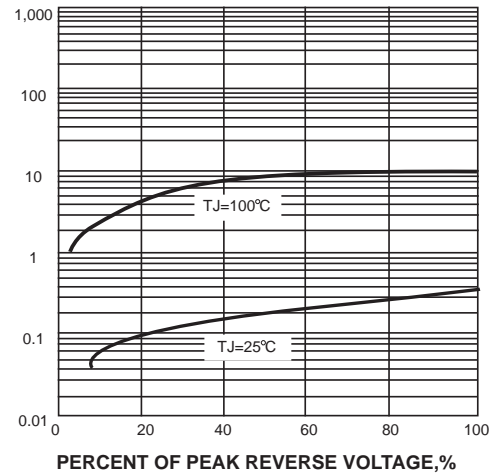

JUNCTION CAPACITANCE, pF

**FIG. 5-TYPICAL JUNCTION CAPACITANCE**

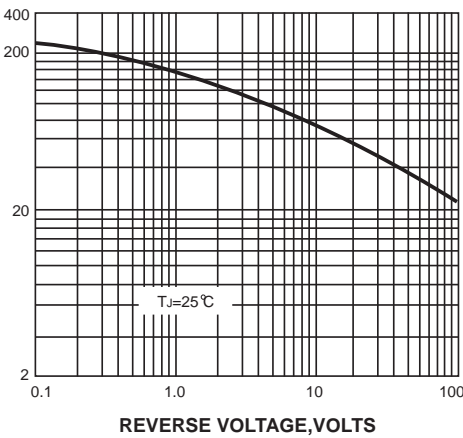

TRANSIENT THERMAL IMPEDANCE, °C/W

**FIG. 6-TYPICAL TRANSIENT THERMAL IMPEDANCE**

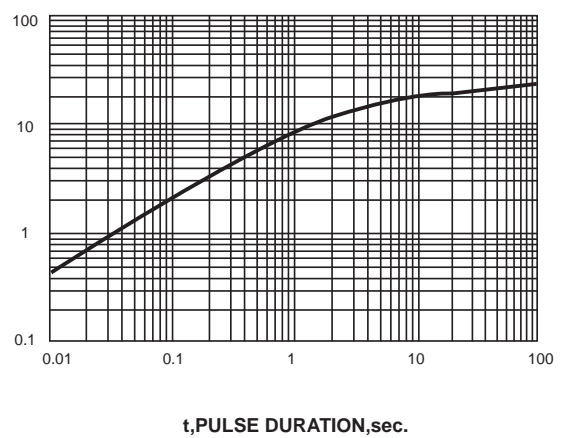

**Marking Diagram**

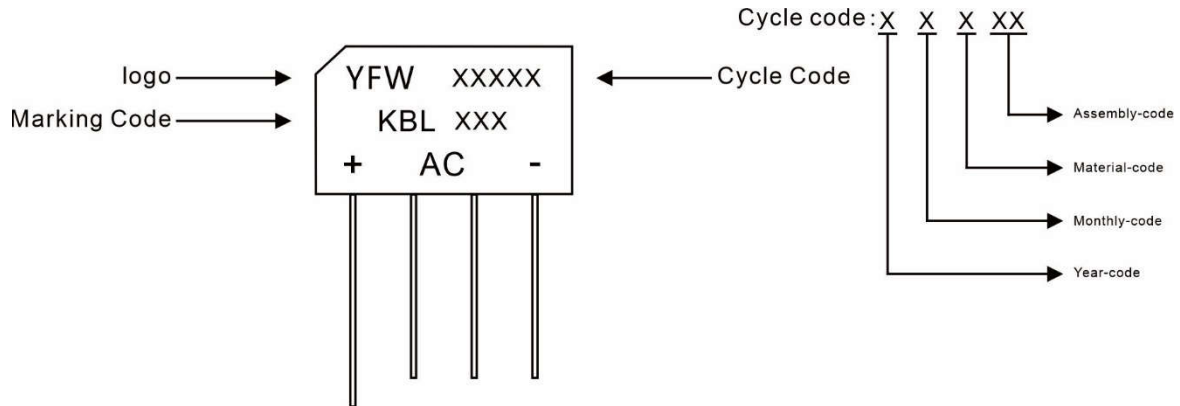

**Ordering information**

Package	Packing Description	Packing Quantity
KBL	bulk	500PCS/Box 3000PCS/Carton

**Package Dimensions**

**KBL**

Dim.	Millimeter(mm)		Dimensions inInch	
	Min.	Max.	Min.	Max.
A	18.5	19.5	0.73	0.77
B	13.9	14.9	0.55	0.59
C	18.0	/	0.71	/
C1	15.0	/	0.59	/
D	5.5	6.5	0.22	0.26
E	4.6	5.6	0.18	0.22
F	1.2	1.3	0.05	0.05
G	15.2	16.3	0.60	0.64
H	1.6	2.0	0.06	0.08

## Disclaimer

The information presented in this document is for reference only. GuangDong Youfeng Microelectronics Co.,Ltd. reserves the right to make changes without notice for the specification of the products displayed herein to improve reliability, function or design or otherwise. The product listed herein is designed to be used with ordinary electronic equipment or devices, and not designed to be used with equipment or devices which require high level of reliability and the malfunction of which would directly endanger human life (such as medical instruments, transportation equipment, aerospace machinery, nuclear-reactor controllers, fuel controllers and other safety devices), YFW or anyone on its behalf, assumes no responsibility or liability for any damages resulting from such improper use of sale. This publication supersedes & replaces all information previously supplied. For additional information, please visit our website <https://www.yfwdiode.com>, or consult YFW sales office for further assistance.